

JMHB80H-2

Komatsu Hydraulic Breaker



New key asset for all jobsites

- ✓ Designed for 5 to 12 tons carriers.
- ✓ Powerful, safe and compact.
- ✓ Landscaping, demolition, trenching, civil engineering, inside and outside: versatile and efficient.

- **Hydraulic accumulator:** no more regular nitrogen controls and recharges on jobsites.
- **Tie rod free:** less weight and cost, more power and reliability.
- **Made in France:** superior quality steel and manufacturing excellence.
- **Improved soundproofing:** lower noise levels for urban jobsites.
- **Easy handling:** two lifting points to handle the breaker with perfect balance and safety, also acting as hoses protection.
- **Tool changing:** new user friendly, simple, safe and reliable system, with one single retainer.

Weight and dimensions

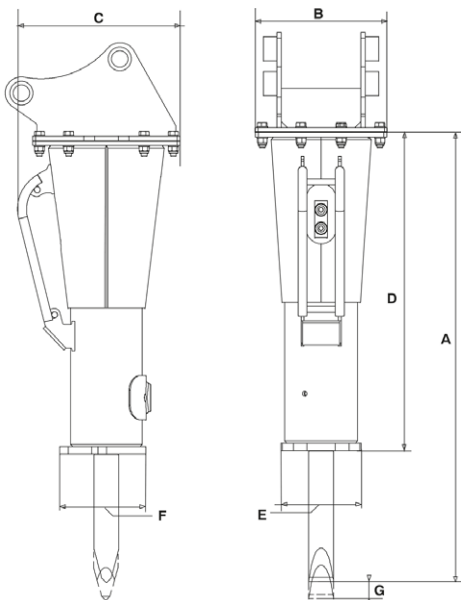

Weight kg/lb

Breaker.	331	761
+ Mounted tool.	365	836
+ Mounted adapter plate (max.)	456	1,005

Dimensions mm/in

A.	1,494	59
B.	442	17
C.	556	22
D.	1,059	42
E.	270	11
F.	295	12
G.	48	2

General specifications

Operating Information

- **Carrier weight range (min-max, mt)** 5 - 12.
- **Oil flow (min-max, l/min / gpm)** 70 - 120 / 18.5 - 32.
- **Operating pressure (max, bar/psi)** 125 / 1,815.
- **Back pressure (max, bar/psi)** 20 / 290.
- **Input power (kw)** 25.
- **Striking frequency (min-max, bpm)** 700 - 1,440.
- **Noise level /10m (dba)** 93.
- **Soundproofing** standard.
- **Hose protection** standard.

Options (CPN)



- **Adapter plate:** Upon request.
- **Special painting:** Upon request.

Maintenance kits (CPN)

- **Level 1:** 101112797.
- **Level 2:** 101112798.
- **Level 3 (+2 warranty years*):** 101112799.

Consumables (CPN)

- **Grease cartridges (X48)** 86799152.

Tools			
Diameter (mm/in).	84 / 3.3	84 / 3.3	84 / 3.3
Length (mm/in).	785 / 31	785 / 31	785 / 31
Weight (kg/lb).	32 / 71	32 / 71	34 / 75
CPN.	86665338	86665361	86685047

The product designs, specifications and information in this document are provided for informational purposes only and do not constitute warranties of any kind. Product designs and specifications may change at any time without prior notice. The only warranties that apply to the sale of products and services are Komatsu's standard written warranties, which will be provided upon request.

Komatsu and other trademarks used in this document are the property of Komatsu Ltd., Komatsu America Corp., Komatsu Mining Corp. or one of their subsidiaries, or their respective owners or licensees.

KOMATSU

komatsulatioamerica.com

