

## JMHB230V-1

Komatsu Hydraulic Breaker



### Cutting-edge technology ruthless for rocks

- ✓ Designed for 18 to 30 tons carriers.
  - ✓ Automatic energy per blow adjustment.
  - ✓ Autonomous working pressure control.
  - ✓ 4.0 breaker.
- **Hydraulic accumulator:** no more regular nitrogen controls and recharges on jobsites.
  - **Made in France:** superior quality steel and manufacturing excellence.

- **Operator friendly:** lblank firing protection, automatic lubrication, energy recovery system, easy maintenance.
- **Carrier friendly:** anti-vibration dampeners, pressure spikes removal.

### Weight and dimensions

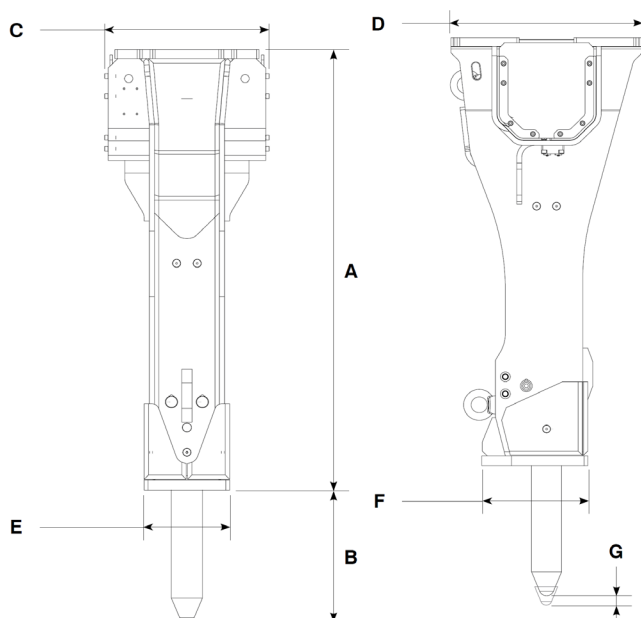

| Weight kg/lb                   |       |       |
|--------------------------------|-------|-------|
| Breaker.                       | 1,217 | 2,683 |
| + Mounted tool.                | 1,332 | 2,936 |
| + Mounted adapter plate (max.) | 1,703 | 3,704 |
| Dimensions mm/in               |       |       |
| <b>A.</b>                      | 1,747 | 68.8  |
| <b>B.</b>                      | 530   | 20.9  |
| <b>C.</b>                      | 638   | 25.1  |
| <b>D.</b>                      | 720   | 28.3  |
| <b>E.</b>                      | 332   | 13    |
| <b>F.</b>                      | 427   | 16.8  |
| <b>G.</b>                      | 60    | 2.3   |

### Operating Information

- **Carrier weight range (min-max, mt)** 18 - 30.
- **Oil flow (min-max, l/min / gpm)** 120 - 170 / 31.7 - 45.
- **Operating pressure (bar/psi)** 135 / 1,958.
- **Back pressure (bar/psi)** 12 / 174.
- **Input power (kw)** 38.3.
- **Striking frequency (bpm)** 285 - 1,050.
- **Noise level /10m (dba)** 94.
- **Automatic lubrication** standard.
- **Soundproofing** standard.
- **Pressurization** preinstalled.

### Consumables (CPN)







- **Grease cartridges (x20)** 86784758.
- **Em22 grease bucket (20 kg)** 86383338.
- **Ab1f grease bucket (18 kg)** 101095008.

### Options (CPN)

- **Pressurization kit:** 86372505.
- **Tunnel version:** Upon request.
- **Antiseismic:** Upon request.
- **Special painting:** Upon request.
- **Adapter plate:** Upon request.

### Maintenance kits (CPN)

- **Level 0:** 86738309.
- **Level 1:** 86813953.
- **Level 2:** 86813961.

| Tools             |  |  |  |  |  |  |
|-------------------|------------------------------------------------------------------------------------|------------------------------------------------------------------------------------|------------------------------------------------------------------------------------|-------------------------------------------------------------------------------------|--------------------------------------------------------------------------------------|--------------------------------------------------------------------------------------|
| Diameter (mm/in). | 122 / 5                                                                            | 122 / 5                                                                            | 122 / 5                                                                            | 122 / 5                                                                             | 122 / 5                                                                              | 122 / 5                                                                              |
| Length (mm/in).   | 1,100 / 43.30                                                                      | 1,300 / 51.18                                                                      | 1,100 / 43.30                                                                      | 1,300 / 51.18                                                                       | 1,100 / 43.30                                                                        | 1,300 / 51.18                                                                        |
| Weight (kg/lb).   | 94 / 207                                                                           | 109 / 240                                                                          | 91 / 201                                                                           | 110 / 243                                                                           | 96 / 212                                                                             | 115 / 254                                                                            |
| CPN.              | 86420783                                                                           | 86449360                                                                           | 86420791                                                                           | 86382082                                                                            | 86421955                                                                             | 86811452                                                                             |

The product designs, specifications and information in this document are provided for informational purposes only and do not constitute warranties of any kind. Product designs and specifications may change at any time without prior notice. The only warranties that apply to the sale of products and services are Komatsu's standard written warranties, which will be provided upon request.

Komatsu and other trademarks used in this document are the property of Komatsu Ltd., Komatsu America Corp., Komatsu Mining Corp. or one of their subsidiaries, or their respective owners or licensees.

# KOMATSU

[komatsulatioamerica.com](http://komatsulatioamerica.com)

